



Thermosiphon KF Series



Description

The Solahart Kf Series is a roof mounted, closed circuit system specifically designed to provide higher efficiency for use in low to medium solar gain areas.

The higher efficiency absorber with its Black Chrome Selective Surface maximises the absorption of available solar energy while the closed circuit design makes it suitable for frost prone or harsh water areas.

The Kf Series features Solahart's revolutionary multi-flow collector which uses a huge 35 risers to extract the maximum amount of energy from the sun.

The double ceramic lined tank has a protective sacrificial anode and the Kf Free Heat features additional protection. The tank is equipped with an electric booster, alternatively an in-line gas booster is available.

Most Kf and Kf Free Heat systems can be installed with the HartStat OTP (over temperature protection) system to prevent over performance during periods of higher solar radiation and lower hot water draw off.

Key Features

- Highly efficient Black Chrome Selective Surface collector for optimum heat absorption
- Multi-flow closed circuit operation makes it suitable for frost prone or harsh water areas
- Stylish slimline design
- Thermosiphon operation minimises maintenance
- Gas booster or electric booster models available
- Double coated ceramic lined tank
- Enhanced protection on Free Heat models
- Free Heat series available in 180 and 300 litre capacities

Key Benefits

- Can save up to 55% to 90% of water heating energy consumption*
- Reliable, low maintenance operation
- Hot water regardless of the weather
- Qualifies for valuable environmental incentives*
- Reduced energy use can save up to 2.0 to 3.6 tonnes of CO₂ emissions per annum*
- Peace of mind with 10/5/5 (Kf Free Heat) and 5/5/5 (Kf Series) year warranties†

* Energy savings of up to 55% to 90% shown are based on Australian Government approved TRNSYS simulation modelling using a medium load. Savings and incentives will vary depending upon your location, type of Solahart system installed, orientation and inclination of the solar collectors, type of water heater being replaced, hot water consumption and fuel tariff. Maximum financial savings off your hot water bill are achievable when replacing an electric water heater on continuous tariff. Refer to solahart.com.au for further information.

† Solahart Warranty Details: 10/5/5 warranty, 10 year cylinder and collectors supply, 5 year parts, 5 year labour; 5/5/5 warranty, 5 year cylinder and collectors supply, 5 year parts, 5 year labour.

Thermosiphon Kf and Kf Free Heat Closed Circuit Systems

These systems are suitable for multiple installations. They are suitable for frost and harsh water regions.

Kf and Kf Free Heat Systems

Model		150 tank	151 system	180 tank	181 system	182 system	220 tank	221 system	222 system	300 tank	301 system	302 system	303 system	440 tank	443 system	444 system
Tank model																
Kf		150J	✓	180J	✓	✓	220J	✓	✓	300J	✓	✓	✓	440J	✓	✓
Kf Free Heat		-	-	180F	✓	✓	-	-	-	300F	✓	✓	✓	-	-	-
Collector model			Kf		Kf	Kf		Kf	Kf		Kf	Kf	Kf		Kf	Kf
No of collectors			1		1	2		1	2		1	2	3		3	4
HartStat OTP	optional	-	✓	-	✓	✓ [‡]	-	NA	✓ [‡]	-	NA	✓ [‡]	✓ [‡]	-	✓ [‡]	✓ [‡]
Storage capacity	litres	150	150	180	180	180	220	220	220	300	300	300	300	400	400	400
	US gal	40	40	48	48	48	58	58	58	80	80	80	80	106	106	106
Boost capacity (electric)	litres	75	75	90	90	90	110	110	110	150	150	150	150	200	200	200
	US gal	20	20	24	24	24	29	29	29	40	40	40	40	53	53	53
Weight empty	kg	56	102	66	108	154	78	124	170	99	145	187	229	148	290	320
	lbs	123	225	146	238	340	172	273	375	218	320	412	505	326	639	705
Weight full	kg	206	256	245	292	338	298	348	394	399	449	495	541	588	730	776
	lbs	454	564	540	644	745	657	767	869	880	990	1091	1193	1296	1609	1711
A - Width*	m	1.40	1.40	1.62	1.62	2.42	1.88	2.04	2.42	2.43	2.43	2.43	3.38	3.41	3.49	4.44
	in	55.1	55.1	63.8	63.8	95.3	74.0	80.3	95.3	95.7	95.7	95.7	133.1	134.3	137.4	174.8
B - Length*	m	0.51	2.63	0.51	2.63	2.63	0.51	1.64	2.63	0.51	1.64	2.63	2.63	0.51	2.63	2.63
	in	20.1	103.5	20.1	103.5	103.5	20.1	64.6	103.5	20.1	64.6	103.5	103.5	20.1	103.5	103.5

* An additional 0.9m (35.4in) should be left on all four sides of the installation for safe access and servicing.

NA - Not available.

[‡] HartStat OTP is mandatory on these models in Australia and New Zealand.

The Kf and Kf Free Heat systems (if installed with a HartStat OTP system) can be installed as a solar preheater with an inline Solahart gas booster water heater. Refer to the Solahart gas booster specification sheet for further details on the gas booster.

Kf Collector

Aperture (heating) area	m ²	1.87	ft ²	20	
Dimensions	length	mm	1937	in	76.3
	width	mm	1022	in	40.3
	height	mm	77	in	3.0
Capacity	litres	3.5	US gal	0.9	
Weight*	empty	kg	45	lbs	99
	full	kg	49	lbs	108
Working pressure	kPa	170	psi	24	
Absorber surface	Chromonyx selective surface				
Absorber material	steel				
Riser material	steel				
Number of risers	35				
Tray material	0.7mm aluminium				
Insulation material (base)	38mm glass wool blanket				
Glass	3.2mm tempered low iron				

* Weight includes fittings

Kf and Kf Free Heat

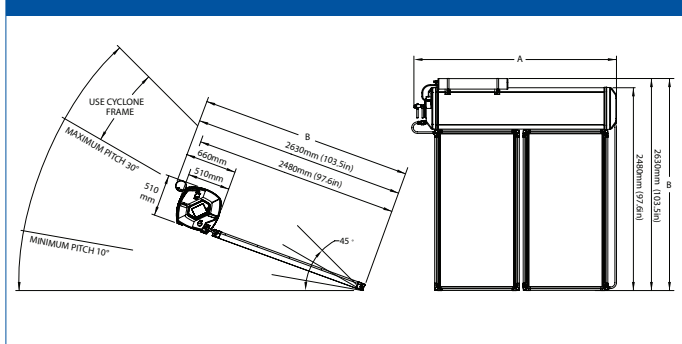

Electric Boost Specifications

Heating unit type*	Copper sheath immersion element			
Supply voltage	220 V – 250 V			
Recovery rate @ 240 V and temperature rise of:				
Rating kW	Current Amps	30°C litres/hour	40°C litres/hour	50°C litres/hour
1.8	8	51	39	31
2.4	10	68	52	41
3.6	15	103	77	62
4.8	20	137	103	83

* A bobbin element (2.5 kW) is available for hard or corrosive water areas.

Gas Boost (In Tank - Optional) Specifications

Model type*	FD15 gas booster fan forced			
Burner rating - Input/Output	13 MJ/h / 10 MJ/h (2.8kW)			
Recovery rate	59 litres per hour @ 40°C rise			
Primary voltage	220 V – 250 V			
Secondary voltage	12 V DC			

* Suitable for hard or corrosive water areas. NA in NSW, QLD

Water Supply

TPR valve setting	kPa	1000	psi	145
ECV* setting	kPa	850	psi	125
Max. supply pressure with ECV	kPa	680	psi	100
	kPa	800	psi	115
Water Connections	cold	Rp 3/4		
	hot	R 1/2		

* Expansion Control Valve.

Technical data is subject to change.