

TECHNICAL SPECIFICATIONS

CONTROLLER RANGE

Part #		c15ts12	c15ts10	c15ts08
Dimensions				
Overall Length	m	3.64	3.04	2.42
Absorber Width	m	1.21	1.21	1.21
Header Length	m	1.29	1.29	1.29
Gross Area	m ²	4.395	3.666	2.917
# Flow Channels		104	104	104
Flow Rates				
Max	l/min	37.86	37.86	37.86
Min	l/min	11.36	9.47	9.47
Rec	l/min	18.55	18.55	18.55
Performance				
FSEC Rating / m ²	BTU	10828	10828	10828
Wind Load	Km/H	241.4	241.4	241.4
Weight				
Dry	Kg	13.15	10.89	8.62
Wet	Kg	28.35	24.35	20.28

SL3 – Deluxe



The SL3 is used in all standard installations where the Solar System utilises its own separate suction and return from the pool.

SL8 – RT



The SL8 has all the functions of the SL3 with the addition of:

- Filter Pump multi function Timer
- Auto Over-Ride that switches the Filter Pump on if the solar gain is present out of normal filter times
- Manual Over-Ride that locks out the Solar Pump when back washing or cleaning lint pot
- Extra Power Plug that eliminates the expense of having an additional power point fitted

INDUSTRY'S BEST LIFE TIME WARRANTY

- Warranty against damage caused by cockatoos
- No Repair or Replace Clause
- Freeze Damage Included

Sunlover Rigid Panel solar collectors come with a lifetime product warranty – an initial 10 year period, followed by a lifetime pro rata warranty. This is the best warranty and is backed by over 35 years of supply to the industry

OUR RIGID SOLAR PANELS ARE ACCREDITED BY



Pumps

We supply pumps by industry leading manufactures such as Hayward.

Distributed by

Contact Sunlover Heating to find out more about our solar heating range

Head Office 62 Parkhurst Drive Knoxfield VIC 3180 T: 03 9887 2131	New South Wales Unit 2, 20-22 Foundry Road Seven Hills, NSW 2147 T: 02 9838 0000 F: 02 9838 0466	Queensland Factory 6, 7-9 Activity Crescent Molendinar QLD 4214 T: 07 5597 7360 F: 07 5597 7361
---	---	--

www.sunloverheating.com.au Email: sales@sunloverheating.com.au



RIGID SOLAR HEATING

- ✓ SUPERIOR HEAT ABSORPTION
- ✓ MOST DURABLE SOLAR PANEL AVAILABLE
- ✓ FREEZE RESISTANT



COCKATOO AND VERMIN RESISTANT



MULTI AWARD WINNERS

Your pool heating Partner

EXTEND YOUR SWIMMING SEASON TO DOUBLE THE NORMAL PERIOD AND SWIM ANY TIME OF THE DAY



Are you getting the benefit of nature's free solar resource?

Pool water temperatures naturally vary from north to south, from season to season, and even from early morning to night. Sunlover Heating solar systems deliver the 'swim when you want' lifestyle - that adds value to your pool.

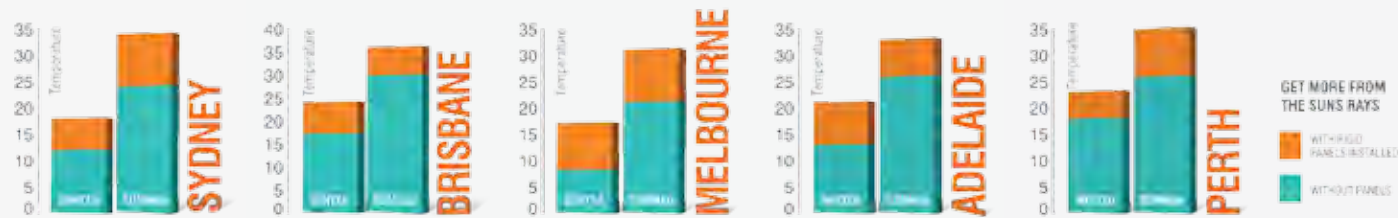

- ✓ FREEZE RESISTANT
- ✓ MOST DURABLE SOLAR PANEL AVAILABLE
- ✓ EFFICIENT DESIGN REDUCES HEAT LOSS
- ✓ HIGH BTU RATING

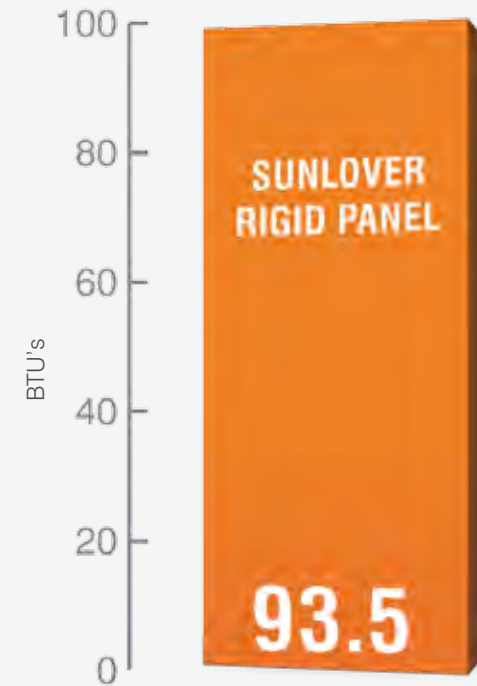

OUR RIGID PANELS HAVE THE HIGHEST BTU RATING IN THE MARKET.

LESS HEAT LOSS MEANS A MORE EFFICIENT SYSTEM

SUNLOVER PANELS HAVE A BTU RATING OF 10,828 BTU/M²

What are BTU's?

BTU's are a unit of measure used to measure thermal (heat) energy. The higher the BTU's the more heat retained by a solar collector. Sunlover collectors have the lowest heat loss because of our connected flow tubes (vs. Conventional individual tubes)

HOW IT WORKS: PROVEN TECHNOLOGY

Heating water with solar absorbers is a proven thermal engineering concept that has been used for centuries.

Solar systems are economical and long life because they are simple – cold water pumped from your pool through solar absorbers on your hot roof collects heat as it makes the return trip to your pool.

The water temperature is managed by an electronic controller.

Today, Sunlover Heating applies state of the art systems design and polymer engineering to its solar absorber products to deliver the lowest cost and most reliable heating you can get for your pool.

CONTROLLING YOUR FREE SOLAR POOL HEATING

Sunlover Heating solar systems are easy to operate with your choice from a range of electronic controllers featuring easy to follow digital readouts.

You set your desired water temperature and desired operating times and forget it. You can also alter your settings at any time for a quick boost of heat, or reduce the pool temperature during a heat wave.

The sophisticated Sunlover Heating digital controllers are reliable Australian made and serviced, and available with optional wireless roof sensor.

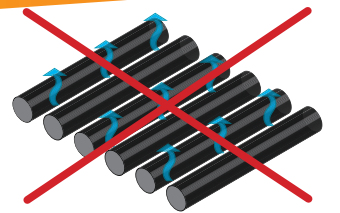
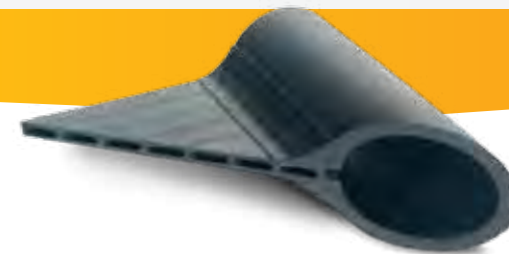
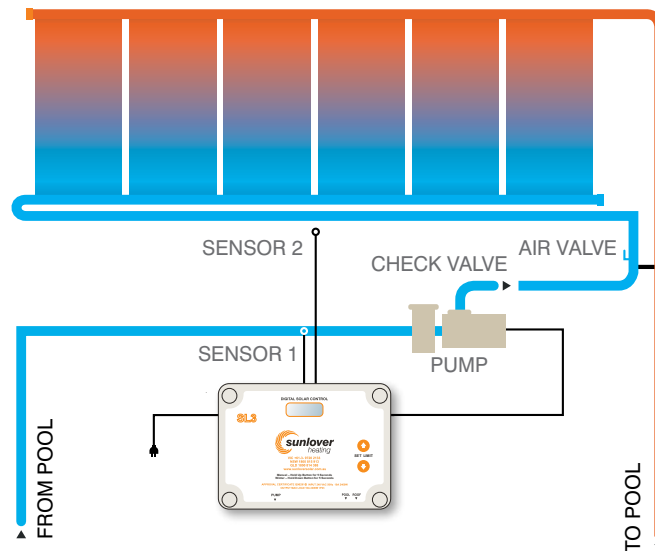

INDESTRUCTIBLE

- ⊕ Fully moulded tubes to the main header for extra strength
- ⊕ Solar collector tubes are manufactured with extra thickness for superior durability & longer life expectancy
- ⊕ The panels are so well built that they can withstand the strength of a 241 km/h cyclone

HIGH EFFICIENCY

- ⊕ Interconnected flow tubes to prevent heat loss
- ⊕ Every panel is factory pressure tested for strength & leaks
- ⊕ Once the panels are installed, there is no additional maintenance or cost.

NOT LIKE TYPICAL RIGID SOLAR

Other Panels allow heat to escape between the tubes, cooling the flowing water down.

COCKATOO AND VERMIN RESISTANT